

Contents

ENGLISH	2
Vehicle Details.....	2
Installation Precautions	4
Parts View	5
Pre Installation	6
Installation	6
Drive Belt.....	7

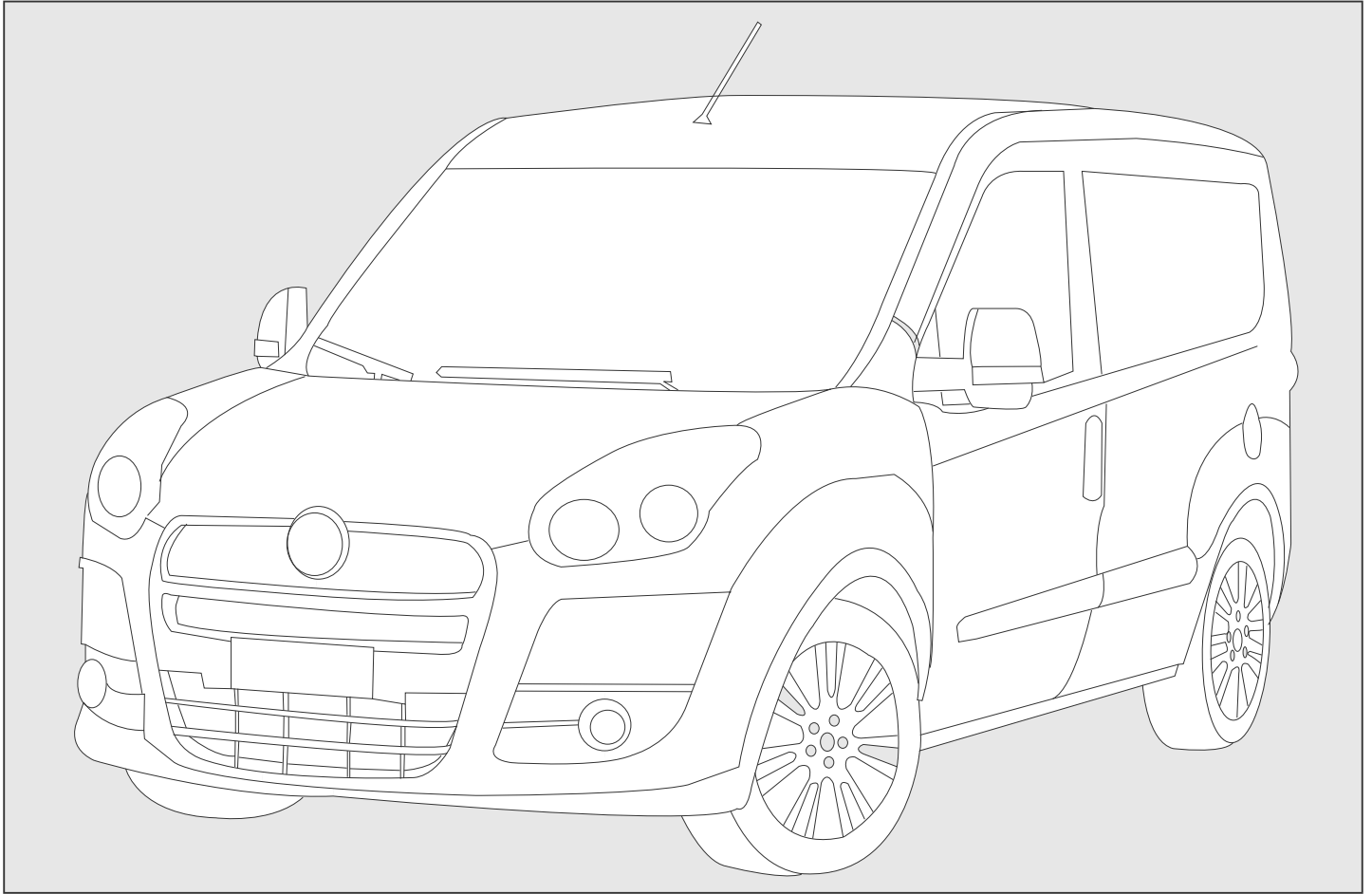

VEHICLE DETAILS

Manufacturer	Fiat / Opel /Vauxhall
Make	New Doblò Cargo / Combo
Model	1.3 Multijet 90 PS / 1.3 CDTi 90 PS
Engine CC	1248
Engine Details	Euro 5 SDE
Year	08.2011 >
Chassis Nos.	N/A
LHD	YES
RHD	YES
PAS	YES
A/C	NO
Voltage	12v

KIT DETAILS

Kit Part No.	0500.6162
Description	Speed Reduction Kit
Compressor RPM	3925 @ Max Engine
	Power Output
Fitting Time	60 Minutes
Suction Fitting	45°
Discharge Fitting	45°
Belt Type	6PK 1744
Belt Part No.	0820.2621

RECOMMENDED COMPRESSORS

SELTEC	TM-13 HS	TM15-HS	TM16-HS
Comp No	0381.0492	-	-
Seltec No.	48844120	-	-
Mounting	Ear	-	-
Rotor	1A	-	-
Armature	SL	-	-
Diameter	126	-	-
Voltage	12	-	-
Orientation	V	-	-
Fitting	3/4 x 7/8	-	-
Manifold	Bolt	-	-

QUE	QP13-HD	QP15-HD	QP16-HD
Comp No	0391.0492	-	-
Que No.	-	-	-
Mounting	Ear	-	-
Rotor	1A	-	-
Armature	SL	-	-
Diameter	126	-	-
Voltage	12	-	-
Orientation	V	-	-
Fitting	3/4 x 7/8	-	-
Manifold	Bolt	-	-

SANDEN	SD5H09	SD5H14	SD5H15
Comp No	-	-	-
Sanden No.	-	-	-
Mounting	-	-	-
Rotor	-	-	-
Armature	-	-	-
Diameter	-	-	-
Voltage	-	-	-
Orientation	-	-	-
Fitting	-	-	-

Notes

COMPRESSOR KIT CONFIGURATIONS

PART NUMBER	COMPRESSOR KIT PART NOS				DESCRIPTION	QTY
	0513.6162	0593.6162	,	,		
0381.0492	●				TM13 Ear Mount 1A SL 126 12V V 3/4 x 7/8 Bolt	1
0391.0492		●			QP13 Ear Mount 1A SL 126 12V V 3/4 x 7/8 Bolt	1

● = Additional parts to standard kits.

FOREWORD

- The purpose of this manual is to facilitate the installation of a direct drive compressor. The information given is merely instructive, should any complications arise contact the Technical department. The manufacturer's warranty does not cover any problems caused by defective installation or alterations made unless authorised. The manufacturer shall not be responsible for any injury, damage or loss caused directly or indirectly as a result of using this manual or the information contained within it.

1 SAFETY MEASURES:

Before fitting the Compressor adapter drive kit, ensure the following for damage:

- Inner and outer trim and body work
- Engine idle pace
- Check all the vehicle functions

Check list:

- Ensure that the right kit has been selected
- Before installing, check that all the correct pieces are present; also ensure that there are no missing or broken pieces
- When fitting, make sure the vehicle is properly protected against damage.

Installation apparatus

- Calibrated torque wrench
- Hand service tools
- Protective covers and shields

2 PRECAUTIONS

- Detach the battery negative lead.
- Torque all bolts where stated using a calibrated torque wrench.
- Take extreme care with moving parts.
- Remove the vehicles ignition key and keep it with you.
- Wear eye safeguards to make sure that liquid refrigerant never touches your skin





Caution: Measures must be followed accurately to steer clear of the possibility of damage to individuals

Warning: This calls awareness to actions which must be pursued to avoid damage to the components.

NB: This calls awareness to make the job easier or gives useful information.

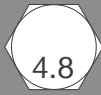
STANDARD FASTENER TORQUE VALUES

- In the absence of specific torque values detailed in this fitting instruction manual, the following chart can be used as a guide to the maximum safe torque for specific size and grade of fastener.

STRENGTH								
	Max Torque		Max Torque		Max Torque		Max Torque	
Dia / Pitch	lb.ft	Nm	lb.ft	Nm	lb.ft	Nm	lb.ft	Nm
M5 x 0.80	2	3	4.5	6	6.5	9	7.5	10
M6 x 1.00	4	5.5	7.5	10	11	15	13	18
M8 x 1.25	10	13	18	25	26	35	33	45
M10 x 1.25	20	27	39	53	57	78	66	90
M10 x 1.50	18	25	37	50	55	73	63	86
M12 x 1.75	33	45	63	85	97	130	111	150
M14 x 2.00	55	75	103	140	151	205	177	240
M16 x 2.00	85	115	159	215	232	315	273	370

PARTS VIEW

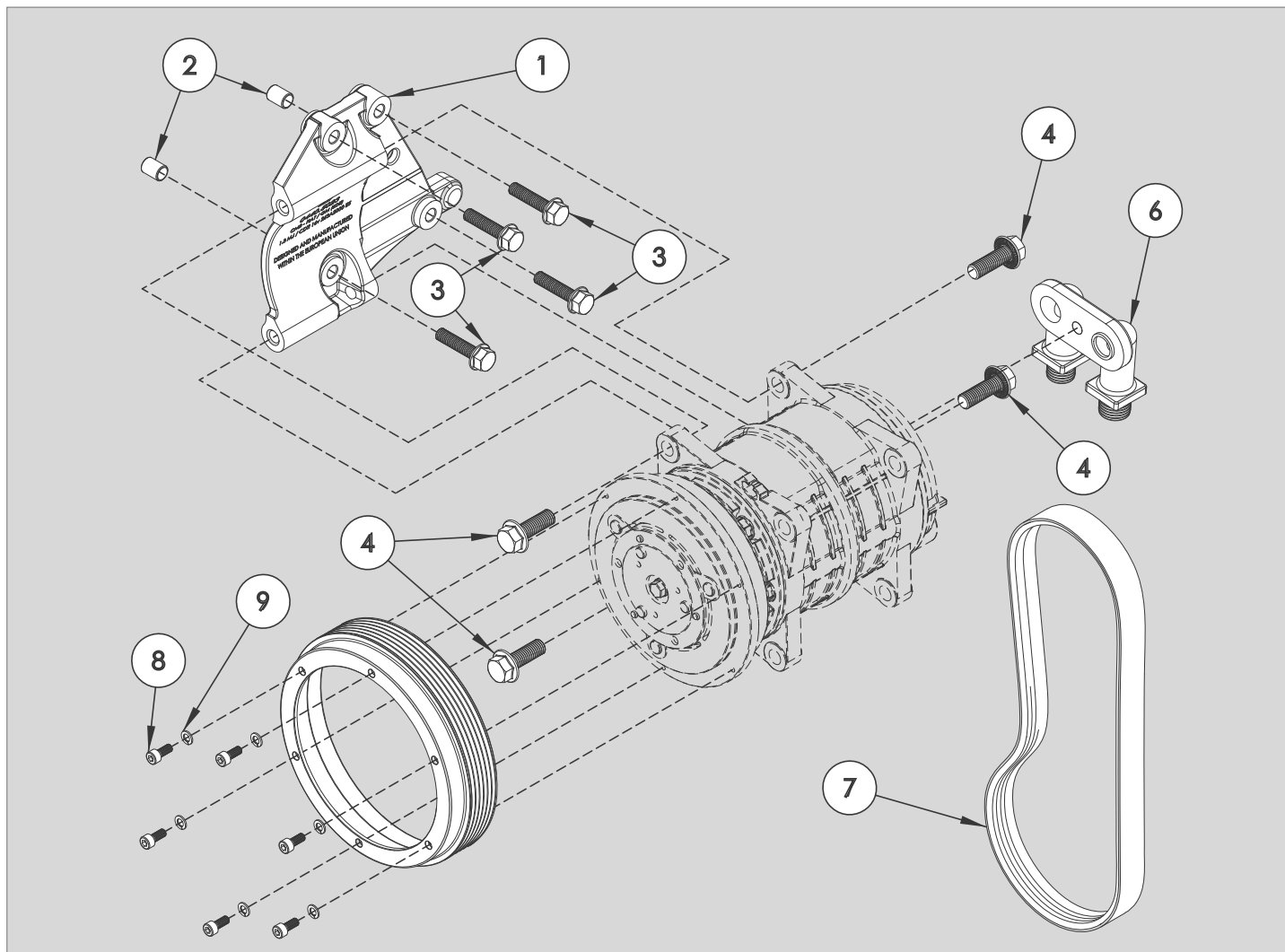

ITEM	PART NO.	DESCRIPTION	QTY.	COMMENTS
1	0440.5023	Compressor Mount Bracket	1	-
2	2800.0311	Dowel Bush	2	-
3	2704.0481	Hex Flange Bolt Durlok - M8 x 35 : 1.25 - 12.9	4	-
4	2705.0491	Hex Flange Bolt Durlok - M10 x 30 : 1.50 - 12.9	4	-
5	0411.5043	Clutch Rotor - PV6 160 Dia GL 32.55 - Seltec / QUE	1	-
6	0425.0251	Manifold Inverted - 3/4 x 7/8 Insert O-Ring	1	-
7	0820.2621	Belt - Poly Groove 6PK 1744	1	-
8	2716.0031	Hex socket head cap screw - M5 x 12 - 0.80	6	-
9	2805.0031	Spring Washer M5 x 1 - ID 5.1 OD 9.2	6	-

PRE-INSTALLATION

N.B Prior to commencing work, please examine the instructions with care. The alphabetical symbols on the diagram relate to written instructions, numerical symbols relate to the parts listing.

NB: Please refrain from using “Loctite” unless otherwise notified.

1. Release the automatic tensioner.
2. Remove and discard drive belt.
3. Remove the wiring loom and support bracket **(A)** from the engine block and secure.- Fig 1

INSTALLATION

1. Install the supplied inverted manifold **(6)** to the compressor **(B)** using the original bolt **(C)** - Fig 2
2. Torque bolt **(C)** to 25Nm / 18Lb.ft

3. Fit the two supplied dowel bushes **(2)** to the mount bracket **(1)** - Fig 3
4. Fit the mount bracket assembly **(1)** to the engine block using four M8 x 35 Flange Bolts **(3)** - Fig 3
5. Torque bolts **(3)** to 35Nm / 26Lb.ft

6. Fit the compressor **(B)** to the mount bracket assembly **(1)** and secure with the four supplied M10 x 30 **(4)** flange bolts - Fig 4
7. Torque flange bolts **(4)** to 50Nm / 36Lb.ft

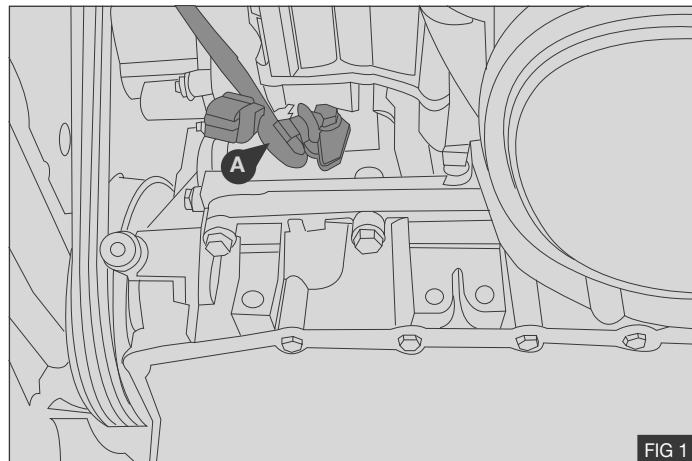

FIG 1

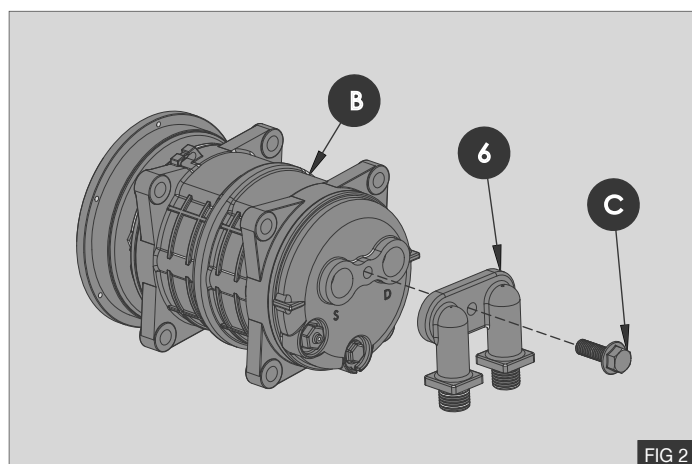

FIG 2

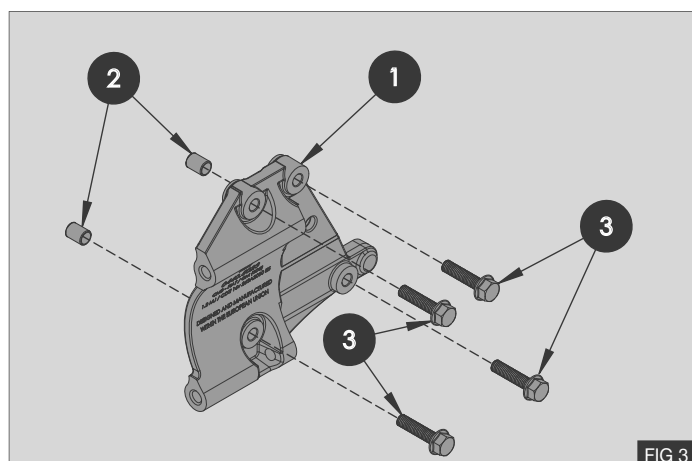

FIG 3

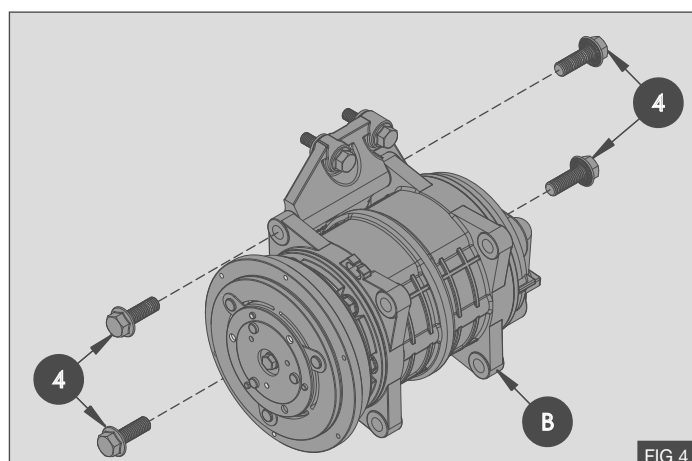
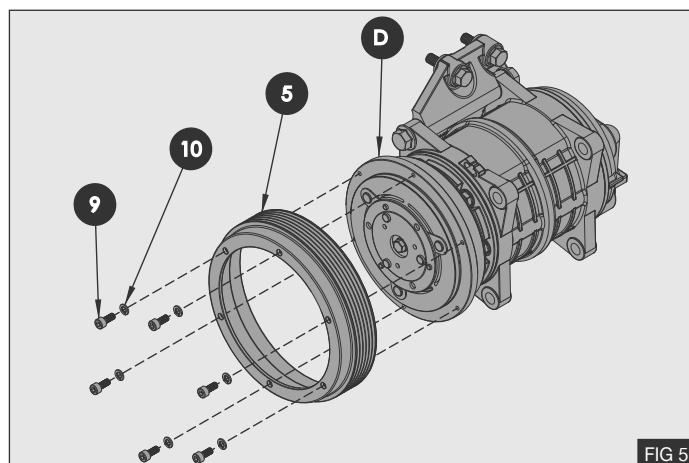

FIG 4

8. Fit the supplied speed rotor (5) to the compressor clutch (D) using 6 x M5 cap head screws (9) and M5 spring washers (10) - Fig 5
9. Torque M5 cap screws (9) to 6Nm / 4.5Lb.ft

Caution: When the speed rotor has been fitted check clearance between the rotor and the radiator hoses. The hose clearance should be greater than 15mm at its closest point. If the clearance is less than 15mm adjust the position of the hose onto the radiator to obtain at least 15mm clearance.



DRIVE BELT

1. Install the supplied drive belt (7) - Fig 6.

- A. Crank Pulley
- B. Tensioner
- C. Alternator
- D. PAS Pump
- E. Idle Pulley
- F. Water Pump
- G. Compressor

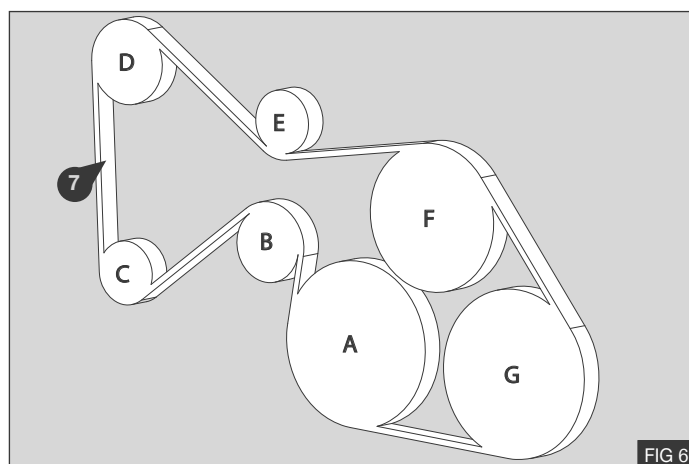

FINISH

Run the engine with the compressor clutch engaged for five minutes, check all components and fit belt label stickers.